

NXR Series Thermal Overload Relays

Applicable scope

NXR thermal overload relays (hereinafter abbreviated as thermal relays) are suitable for overload and phase loss protection for uninterrupted or intermittent AC motors with AC frequency of 50 Hz/60 Hz, a voltage up to 690 V, and a current of (0.1-630)A.

The thermal relays also provide temperature compensation, action indication, automatic and manual reset, stop, and testing functions. The products are characterized by stable and reliable performance. The thermal relays can be plugged into contactors or installed independently.

Compliant standards: IEC/EN 60947-4-1, IEC/EN 60947-5-1.

Structural characteristics

- Three-phase bi-metal sheet type or electronic type (NXR-200, NXR-630) Tripping
- With phase loss protection
- With a device for continuous adjustment of setting current
- With temperature compensation
- With action indication
- With testing mechanism
- With stop bottom
- With manual and automatic reset button (NXR-200 and NXR-630 only have manual reset)
- With one NO contact and one NC contact that are electrically separable
- Installation method: Plugged into contactor (NXR-12, 25, 38, 100) or installed independently (NXR-200, 630)
- Protection characteristics

Operation environment

Type	Operation and installation conditions
Installation type	III
Pollution degree	3
Compliant standards	IEC/EN 60947-4-1, IEC/EN 60947-5-1
Certification mark	CE
Enclosure protection degree	IP20 (NXR-12, 25, 38, 100)
Ambient temperature	Operation temperature limits: -35°C ~ +70°C. Normal operation temperature range: -5°C ~ +40°C. The 24-hour average temperature should not exceed +35°C. For use beyond the normal operation temperature range, see "Instructions for use in abnormal conditions" in the annex.
Altitude	Not exceeding 2000m above sea level
Atmospheric conditions	The relative humidity should not exceed 50% at the upper temperature limit of +70°C. A higher relative humidity is allowed at a lower temperature, e.g. 90% at +20°C. Special precautions should be taken against occasional condensation due to humidity variations.
Installation conditions	The angle between the installation surface and the vertical surface should not exceed ±5°.
Shock and vibration	The anti-shock performance conforms to the allowable acceleration of IEC60068-2-7: 15gn-11m; The anti-vibration performance conforms to the allowable acceleration of IEC60068-2-6: 6gn





Type Designation

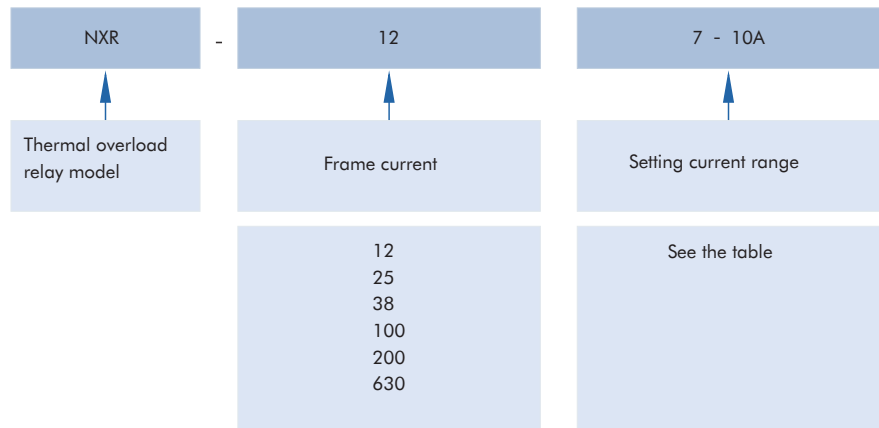

Frame	Setting current
12	0.1-0.16A
	0.16-0.25A
	0.25-0.4A
	0.4-0.63A
	0.63-1A
	1-1.6A
	1.25-2A
	1.6-2.5A
	2.5-4A
	4-6A
	5.5-8A
	7-10A
9-12A	





Frame	Setting current
25	0.1-0.16A
	0.16-0.25A
	0.25-0.4A
	0.4-0.63A
	0.63-1A
	1-1.6A
	1.25-2A
	1.6-2.5A
	2.5-4A
	4-6A
	5.5-8A
	7-10A
9-13A	
12-18A	
17-25A	

Frame	Setting current
38	23-32A
	30-38A
100	23-32A
	30-40A
	37-50A
	48-65A
	55-70A
	63-80A
200	80-93A
	80-100A
	80-160A
630	100-200A
	125-250A
	200-400A
	315-630A

Selection example:

"NXR-25 7-10A" represents a NXR 3P thermal overload relay with a frame current class of 25 and a setting current range between 7A and 10A.

MB mounting base

Type	Application
 MB-1	Incorporate_with_NXR-12 to be an independant mounted product
 MB-2	Incorporate_with_NXR-25 to be an independant mounted product
 MB-3	Incorporate_with_NXR-38 to be an independant mounted product
 MB-4	Incorporate_with_NXR-100 to be an independant mounted product

Quick selection and matching table

Product appearance	Rated current A	Specification of matching fuse (RT16 recommended) A	Model of matching contactor
		gG	
 <p>NXR-12</p>	0.1~0.16	2	 <p>NXC-06M, 09M, 12M</p>
	0.16~0.25	2	
	0.25~0.4	2	
	0.4~0.63	2	
	0.63~1	4	
	1~1.6	4	
	1.25~2	6	
	1.6~2.5	6	
	2.5~4	10	
	4~6	16	
	5.5~8	20	
	7~10	20	
9~12	25		
 <p>NXR-25</p>	0.1~0.16	2	 <p>NXC-06, 09, 12, 16, 18, 22, 25, 32, 38</p>
	0.16~0.25	2	
	0.25~0.4	2	
	0.4~0.63	2	
	0.63~1	4	
	1~1.6	4	
	1.25~2	6	
	1.6~2.5	6	
	2.5~4	10	
	4~6	16	
	5.5~8	20	
	7~10	20	
9~13	25		
12~18	35		
17~25	50		
 <p>NXR-38</p>	23~32	63	 <p>NXC-25, 32, 38</p>
	30~38	80	
 <p>NXR-100</p>	23~32	63	 <p>NXC-40, 50, 65, 75, 85, 100</p>
	30~40	100	
	37~50	100	
	48~65	100	
	55~70	125	
	63~80	125	
	80~93	160	
80~100	160		
 <p>NXR-200</p>	80~160	315	 <p>NXC-120, 160, 185, 225</p>
	100~200	315	
 <p>NXR-630</p>	125~250	800	 <p>NXC-225, 265, 330, 400, 500, 630</p>
	200~400	800	
	315~630	800	

Parameters

Item		NXR-12	NXR-25	NXR-38	NXR-100	NXR-200	NXR-630	
Current level		12	25	38	100	200	630	
Rated insulation voltage V		690	690	690	690	690	690	
Rated impulse withstand voltage V		8000	8000	8000	8000	8000	8000	
		6000	6000	6000	6000	6000	6000	
Enclosure protection degree		Fronid IP20	Fronid IP20	Fronid IP20	Fronid IP20	-	-	
Phase loss protection		Yes	Yes	Yes	Yes	Yes	Yes	
Manual and automatic reset		Yes	Yes	Yes	Yes	Manual	Manual	
Temperature compensation		Yes	Yes	Yes	Yes	Yes	Yes	
Trip indication		Yes	Yes	Yes	Yes	Yes	Yes	
Test button		Yes	Yes	Yes	Yes	Yes	Yes	
Stop button		Yes	Yes	Yes	Yes	Yes	Yes	
Installation method		Plugged	Plugged	Plugged	Plugged	Independent	Independent	
Integrated auxiliary contact		1NO+1NC	1NO+1NC	1NO+1NC	1NO+1NC	1NO+1NC	1NO+1NC	
AC-15 380V/400V/415V rated current A		1.5	1.5	1.5	1.5	1.5	1.5	
DC-13 220V rated current A		0.2	0.2	0.2	0.2	0.2	0.2	
Conductor cross section mm ²	Main circuit	Single-core or stranded wire	1~4	1~6	4~10	4~35	25~95	50~2×185
		Wiring screw	M3.5	M4	M4	M10	M8	M10
		Tightening torque(N·m)	1.2	1.7	1.7	10	10	20
	Auxiliary circuit	Single-core or stranded wire	1~2.5	1~2.5	1~2.5	1~2.5	1~2.5	1~2.5
		Wiring screw	M3.5	M3.5	M3.5	M3.5	M3.5	M3.5
		Tightening torque(N·m)	0.8	0.8	0.8	0.8	1.2	1.2

Protection characteristics

Item		Multiples of setting current		tripping	Test conditions
Overload protection	1	1.05		Without action in 2 hours	Start from cold state
	2	1.2		Act within 2 hours	Start from hot state (after No. 1)
	3	1.5		Act within 2 minutes	Start after thermal equilibrium is reached under setting current
	4	7.2		2s < Tp ≤ 10s	Start from cold state
Phase loss protection	5	Any two phases	The other phase	Without action in 2 hours	Start from cold state
		1.0	0.9		
	6	1.15	0	Act within 2 hours	Start from hot state (after No. 5)

Trip characteristics

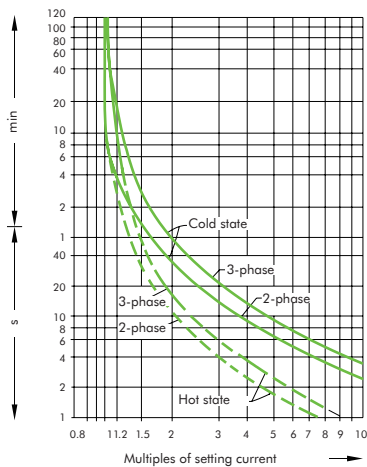

Thermal relay time Vs current characteristics curve (+20°C)

Product front view

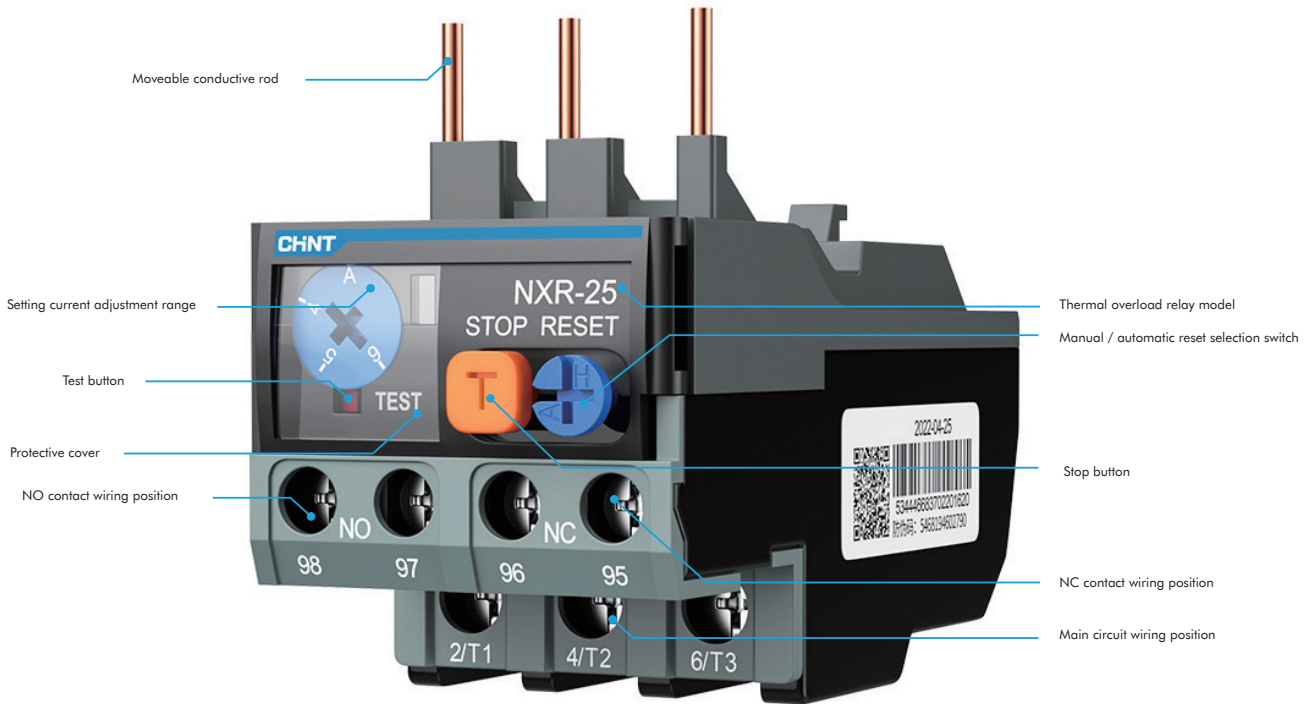

Dimensions and installation

NXR-12

Dimensions and installation

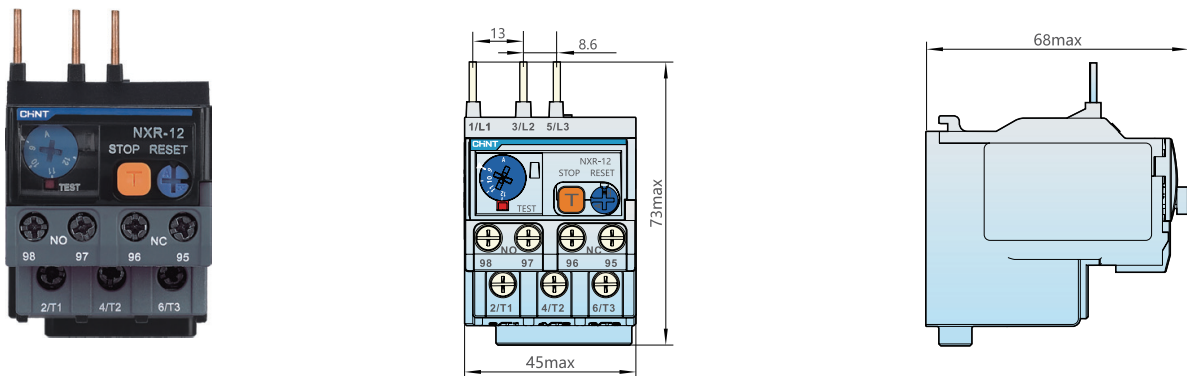

NXR-25

Dimensions and installation

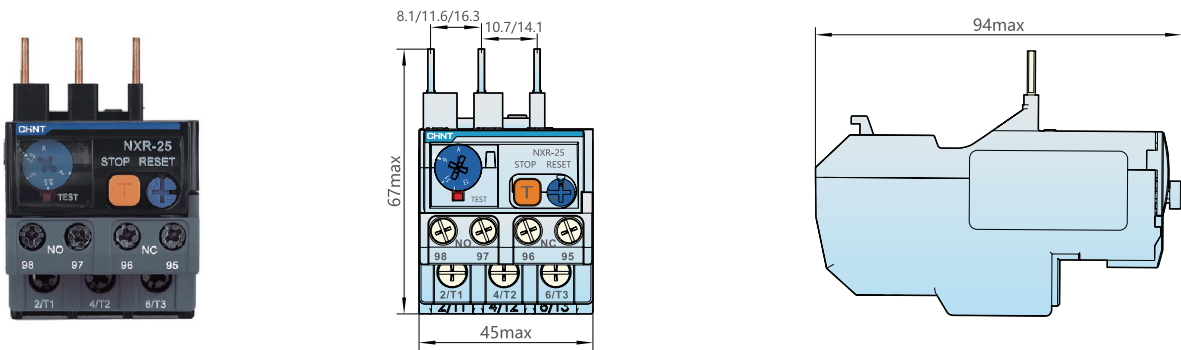

NXR-38

Dimensions and installation

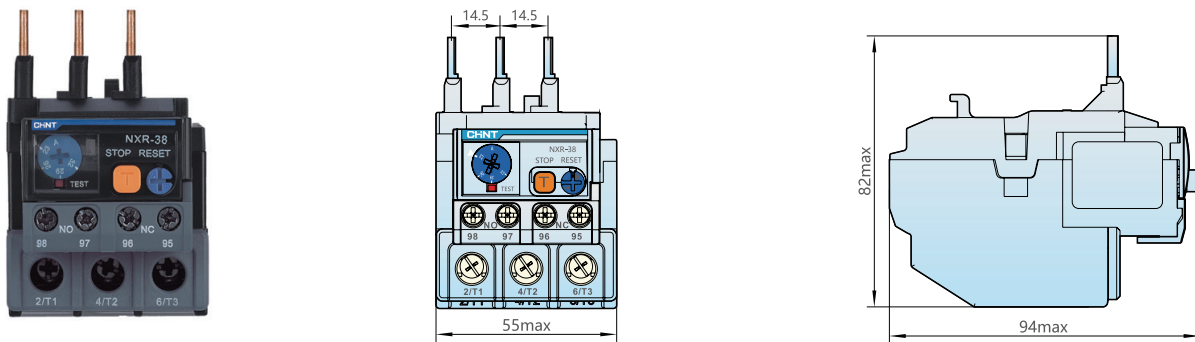

NXR-100

Dimensions and installation

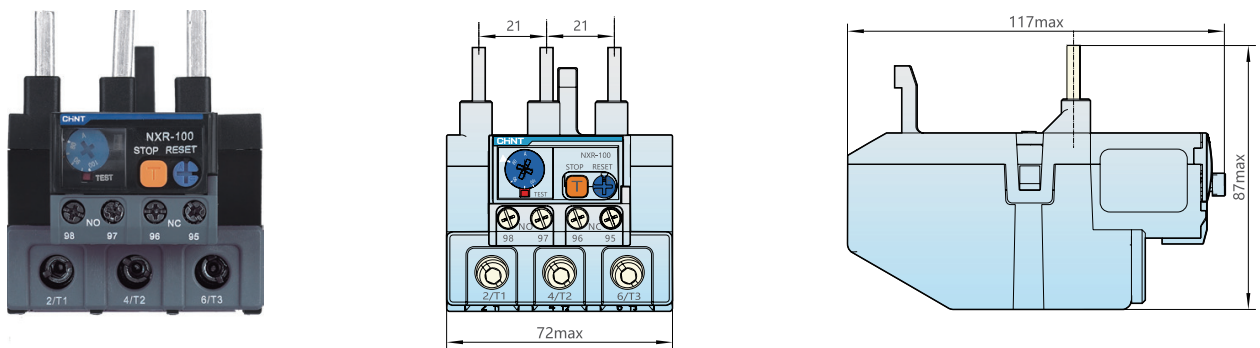

NXR-200

Dimensions and installation

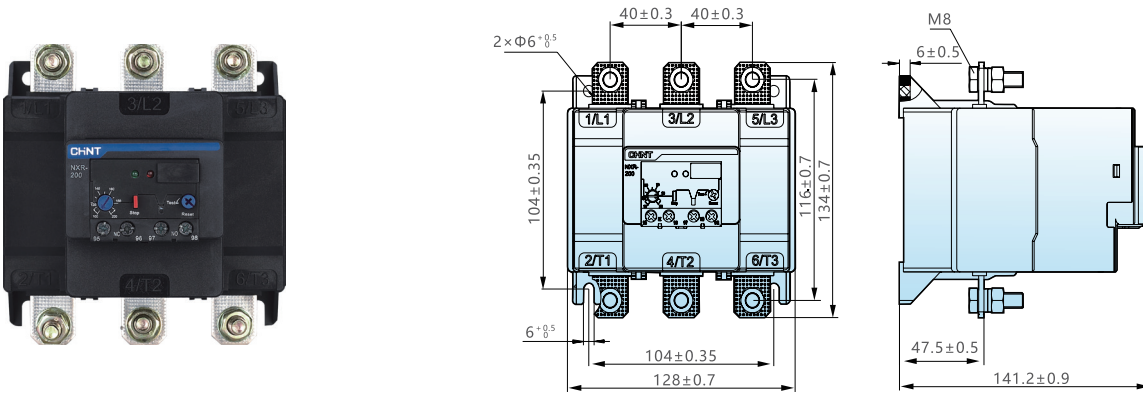

NXR-630

Dimensions and installation

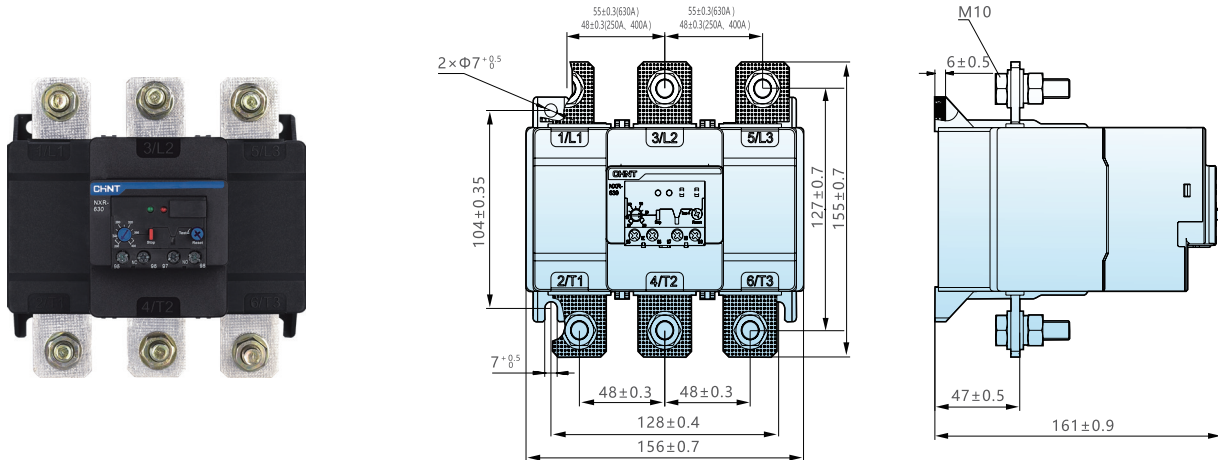

NXC-06M~12M + NXR-12

Dimensions and installation

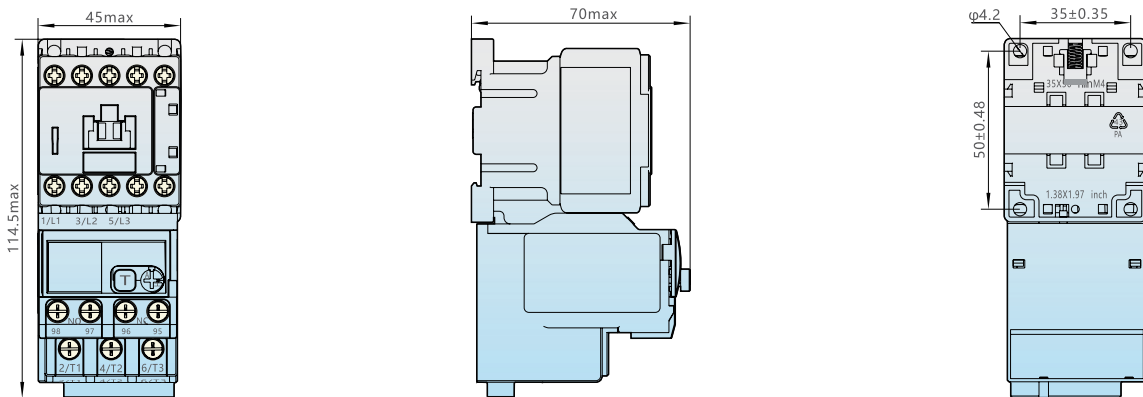

NXR-06~22+ NXR-25

Dimensions and installation

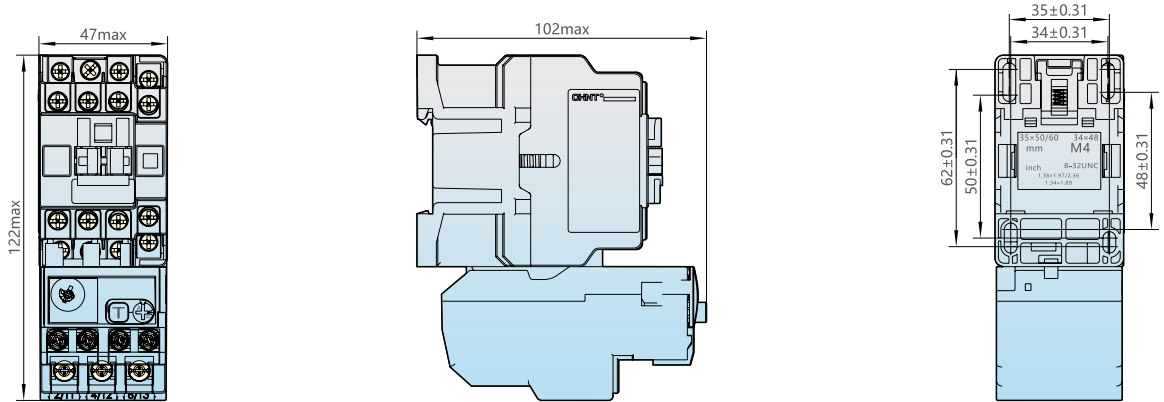

NXR-25~38+ NXR-25

Dimensions and installation

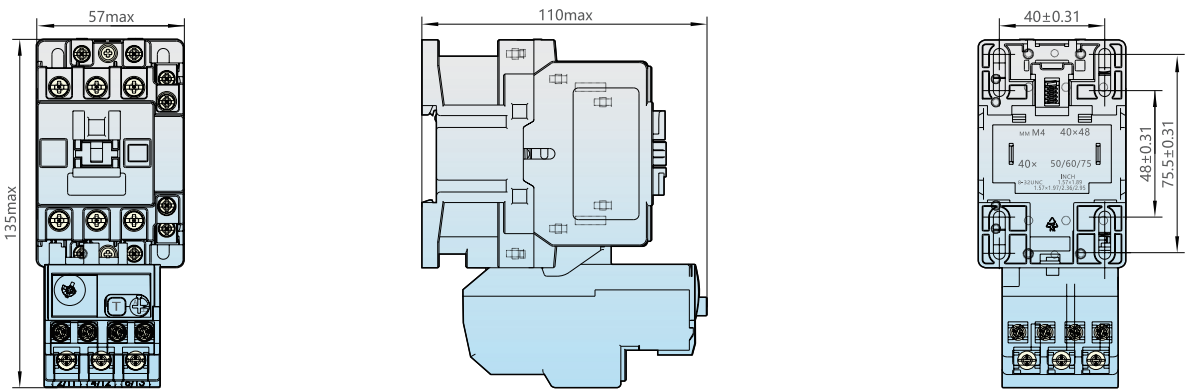

NXR-25~38+ NXR-38

Dimensions and installation

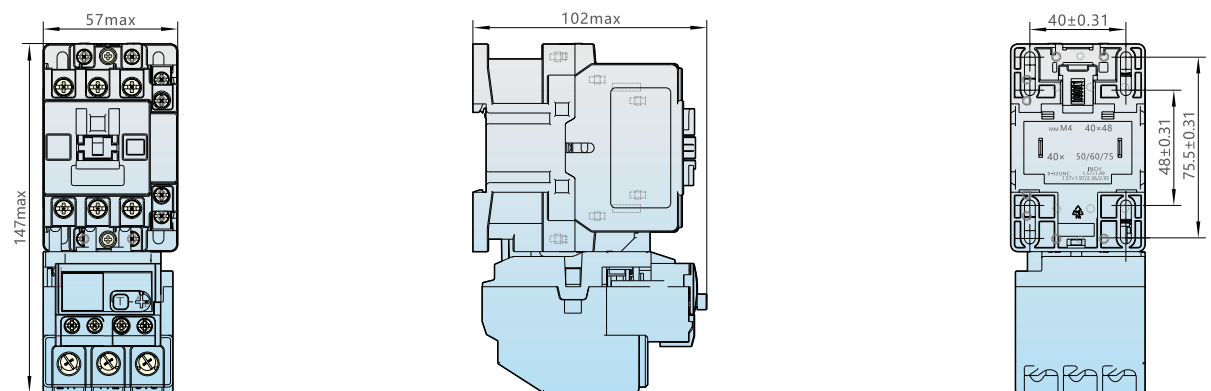

NXC-40~65 + NXR-100

Dimensions and installation

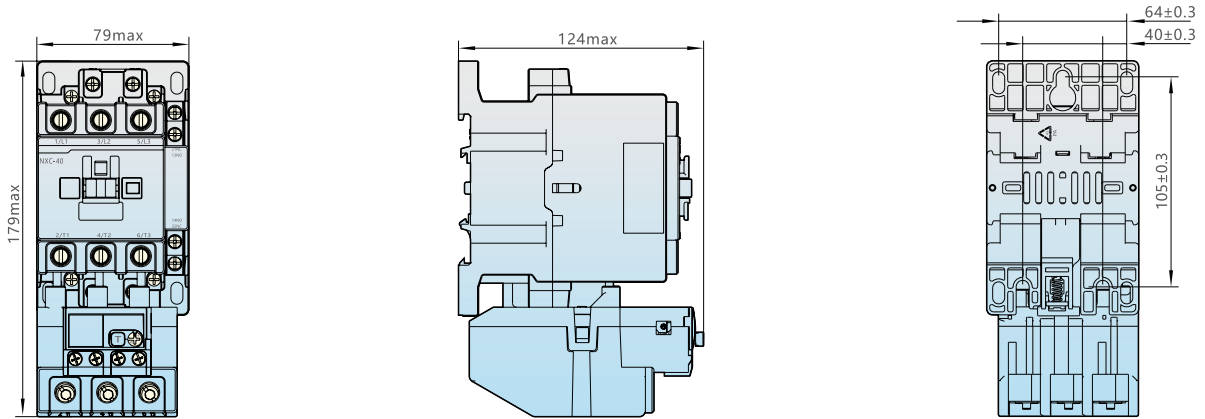

NXC-75~100 + NXR-100

Dimensions and installation

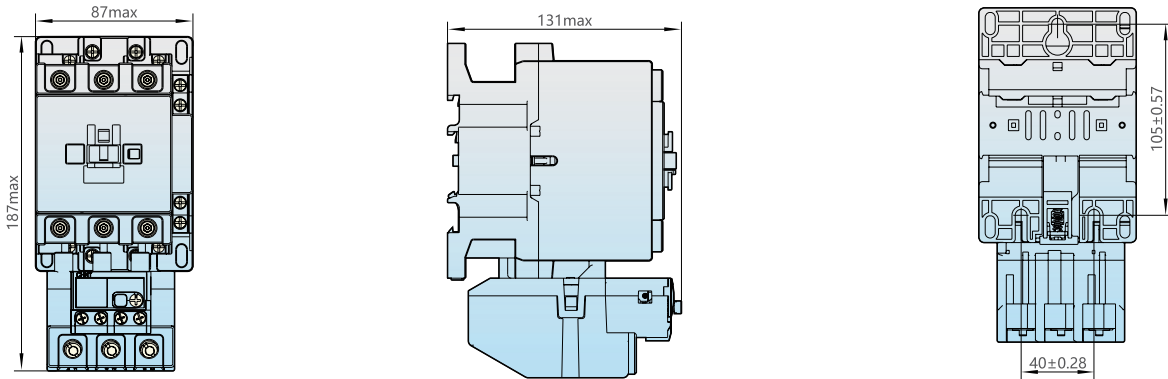

NXR-12 + MB-1

Dimensions and installation

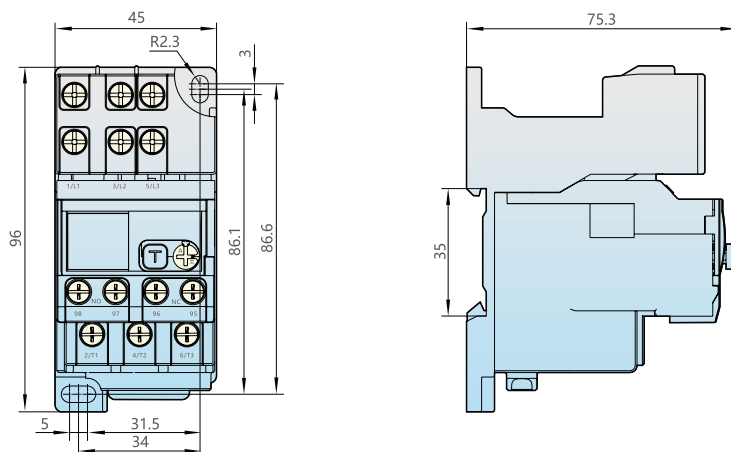

NXR-25+ MB-2

Dimensions and installation

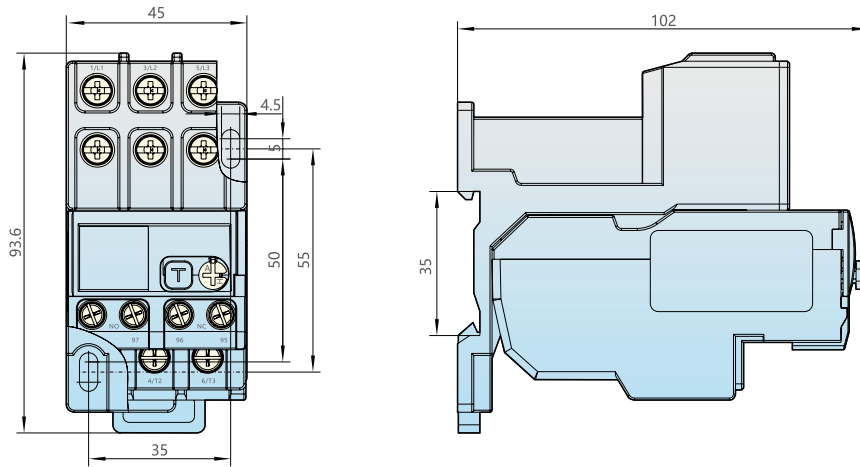

NXR-38+ MB-3

Dimensions and installation

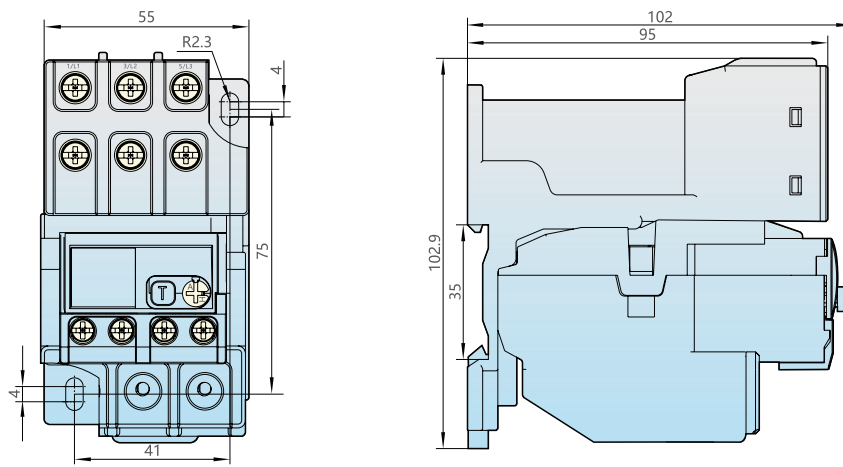

NXR-100+ MB-4

Dimensions and installation

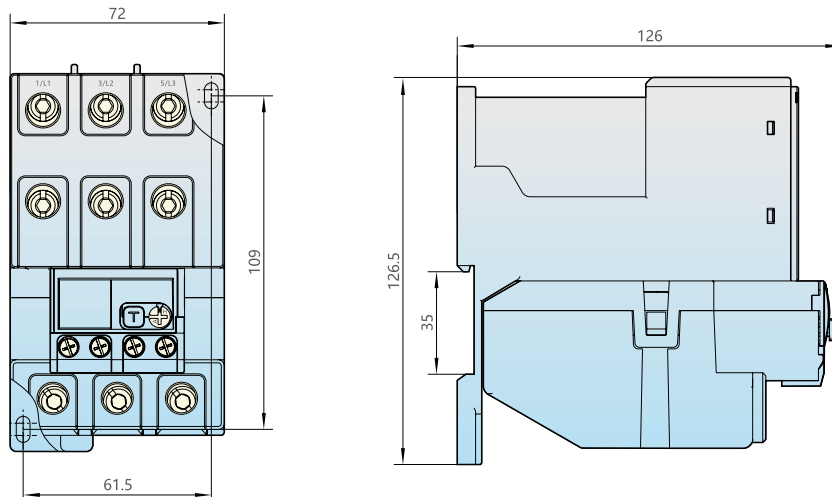

Wiring diagrams

NXR-12~100

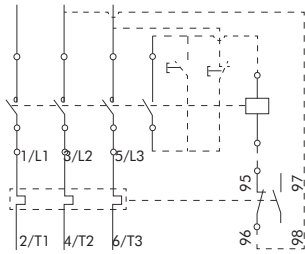

NXR-200~630

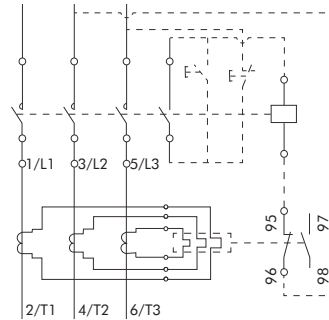

Annex I: Instructions for use in abnormal conditions

- IEC/EN 60947-4-1 standard defines normal operation temperature range for products. Use of products in the normal range will not cause significant impact on their performance.
- At an operation temperature higher than +40°C , the tolerable temperature rise of products needs to be reduced. The rated operation current should be adjusted to prevent product damage, shortened service life, lower reliability, or impact on action characteristics. At a temperature lower than -5°C , impact of changes to the heat dissipation system on the action characteristics of the products should be considered.
- The temperature compensation coefficients at an ambient temperature higher than +40°C and lower than -5°C are given below. The compensation coefficients corresponding to -35°C and +70°C environments are given in the table below. No corrections are required for NXR-200 and NXR-630.

Operation ambient temperature		-35°C	+70°C
Temperature compensation coefficients for NXR-12, 25, 38, 100	Multiple of stable current	1.05	0.9
	Multiple of trip current	1.4	1.2

NXR-12, 25, 38, 100

Temperature compensation curve

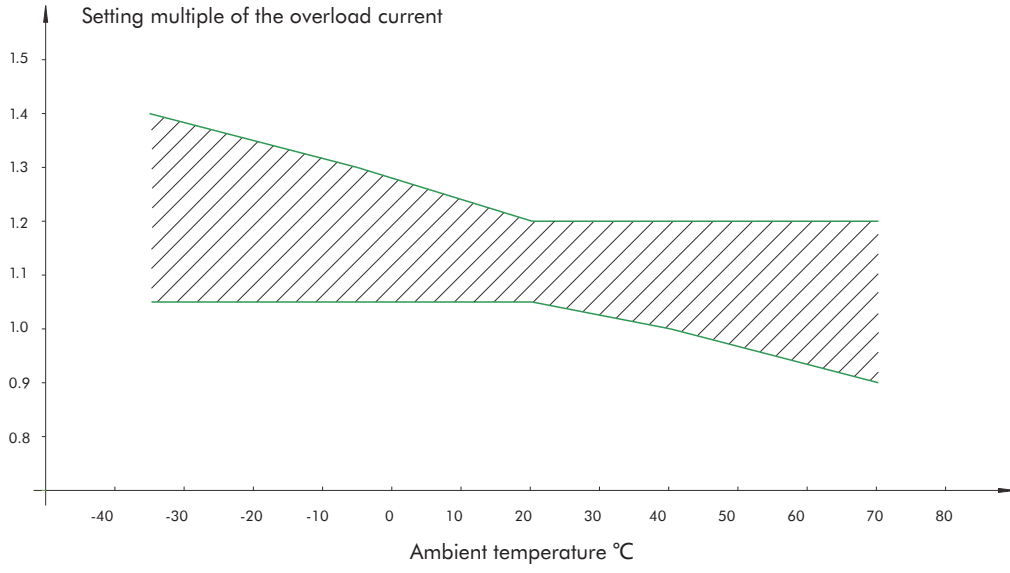

<p>NXR</p>	<p>25</p>	<p>9~13A</p>
<p>Product Series</p>	<p>Frame Size</p>	<p>Setting Current Scope</p>
	<p>12 25 38 100 200 630</p>	<p>Frame Size 12: 0.1~0.16A 0.16~0.25A 0.25~0.4A 0.4~0.63A 0.63~1A 1~1.6A 1.25~2A 1.6~2.5A 2.5~4A 4~6A 5.5~8A 7~10A 9~12A Frame Size 25: 0.1~0.16A 0.16~0.25A 0.25~0.4A 0.4~0.63A 0.63~1A 1~1.6A 1.25~2A 1.6~2.5A 2.5~4A 4~6A 5.5~8A 7~10A 9~13A 12~18A 17~25A Frame Size 38: 23~32A 30~38A Frame Size 93: 23~32A 30~40A 37~50A 48~65A 55~70A 63~80A 80~93A 80~100A Frame Size 200: 80~160A 100~200A Frame Size 630: 125~250A 200~400A 315~630A</p>

NXR Relay 12~630A

Frame Size	Setting Current	Model Description	Code
12A	0.1-0.16A	NXR-12 0.1-0.16A	837092
12A	0.16-0.25A	NXR-12 0.16-0.25A	837093
12A	0.25-0.4A	NXR-12 0.25-0.4A	837094
12A	0.4-0.63A	NXR-12 0.4-0.63A	837095
12A	0.63-1A	NXR-12 0.63-1A	837096
12A	1-1.6A	NXR-12 1-1.6A	837097
12A	1.25-2A	NXR-12 1.25-2A	837098
12A	1.6-2.5A	NXR-12 1.6-2.5A	837099
12A	2.5-4A	NXR-12 2.5-4A	837100
12A	4-6A	NXR-12 4-6A	837101
12A	5.5-8A	NXR-12 5.5-8A	837102
12A	7-10A	NXR-12 7-10A	837103
12A	9-12A	NXR-12 9-12A	837104
25A	0.1-0.16A	NXR-25 0.1-0.16A	837105
25A	0.16-0.25A	NXR-25 0.16-0.25A	837106
25A	0.25-0.4A	NXR-25 0.25-0.4A	837107
25A	0.4-0.63A	NXR-25 0.4-0.63A	837108
25A	0.63-1A	NXR-25 0.63-1A	837109
25A	1-1.6A	NXR-25 1-1.6A	837110
25A	1.25-2A	NXR-25 1.25-2A	837111
25A	1.6-2.5A	NXR-25 1.6-2.5A	837112
25A	2.5-4A	NXR-25 2.5-4A	837113
25A	4-6A	NXR-25 4-6A	837114
25A	5.5-8A	NXR-25 5.5-8A	837115
25A	7-10A	NXR-25 7-10A	837116
25A	9-13A	NXR-25 9-13A	837117
25A	12-18A	NXR-25 12-18A	837118
25A	17-25A	NXR-25 17-25A	837119
38A	23A-32A	NXR-38 23A-32A	837120
38A	30A-38A	NXR-38 30A-38A	837121
100A	23A-32A	NXR-100 23A-32A	837122
100A	30A-40A	NXR-100 30A-40A	837123
100A	37A-50A	NXR-100 37A-50A	837124
100A	48A-65A	NXR-100 48A-65A	837125
100A	55A-70A	NXR-100 55A-70A	837126
100A	63A-80A	NXR-100 63A-80A	837127
100A	80A-93A	NXR-100 80A-93A	837128
100A	80A-100A	NXR-100 80A-100A	837129
200A	80A-160A	NXR-200 80A-160A	837130
200A	100A-200A	NXR-200 100A-200A	837131
630A	125A-250A	NXR-630 125A-250A	837132
630A	200A-400A	NXR-630 200A-400A	837133
	315A-630A	NXR-630 315A-630A	837134